

**Features :**

- Isolated mounting base 3000V~
- Pressure contact technology with  
Increased power cycling capability
- Space and weight saving

**Typical Applications**

- AC/DC Motor drives
- Various rectifiers
- DC supply for PWM inverter

$V_{DSM}, V_{RSM}$	$V_{DRM}, V_{RRM}$	品名
900V	800V	Mx330TH80
1100V	1000V	Mx330TH100
1300V	1200V	Mx330TH120
1500V	1400V	Mx330TH140
1700V	1600V	Mx330TH160
1900V	1800V	Mx330TH180

SYMBOL	CHARACTERISTIC	TEST CONDITIONS	$T_j(^{\circ}\text{C})$	VALUE			UNIT
				Min	Type	Max	
$I_{T(AV)}$	Mean on-state current	180° half sine wave 50Hz Single side cooled, $T_c=85^{\circ}\text{C}$	125			330	A
$I_{T(RMS)}$	RMS on-state current					518.1	A
$I_{DRM}$ $I_{RRM}$	Repetitive peak current	at $V_{DRM}$ at $V_{RRM}$	125			25	mA
$I_{TSM}$	Surge on-state current	10ms half sine wave $V_R=60\%V_{RRM}$	125			9.1	kA
$I^2t$	$I^2t$ for fusing coordination					414.05	$\text{A}^2\text{s}\cdot 10^3$
$V_{TO}$	Threshold voltage		125			0.80	V
$r_T$	On-state slope resistance					0.53	m $\Omega$
$V_{TM}$	Peak on-state voltage	$I_{TM}=990\text{A}$	25			1.45	V
$dv/dt$	Critical rate of rise of off-state voltage	$V_{DM}=67\%V_{DRM}$	125			1000	V/ $\mu\text{s}$
$di/dt$	Critical rate of rise of on-state current	Gate source 1.5A $t_r \leq 0.5\mu\text{s}$ Repetitive	125			200	A/ $\mu\text{s}$
$I_{GT}$	Gate trigger current	$V_A=12\text{V}, I_A=1\text{A}$	25	30		180	mA
$V_{GT}$	Gate trigger voltage			1.0		2.5	V
$I_H$	Holding current			20		150	mA
$V_{GD}$	Non-trigger gate voltage	$V_{DM}=67\%V_{DRM}$	125	0.2			V
$R_{th(j-c)}$	Thermal resistance Junction to case	Single side cooled per chip				0.12	$^{\circ}\text{C}/\text{W}$
$R_{th(c-h)}$	Thermal resistance case to heatsink	Single side cooled per chip				0.03	$^{\circ}\text{C}/\text{W}$
$V_{iso}$	Isolation voltage	50Hz, R.M.S, $t=1\text{min}, I_{iso}: 1\text{mA}(\text{MAX})$		3000			V
$F_m$	Terminal connection torque(M8)				12.0		N-m
	Mounting torque(M6)				6.0		N-m
$T_{vj}$	Junction temperature			-40		125	$^{\circ}\text{C}$
$T_{stg}$	Stored temperature			-40		125	$^{\circ}\text{C}$
$W_t$	Weight				810		g
Outline	M03						

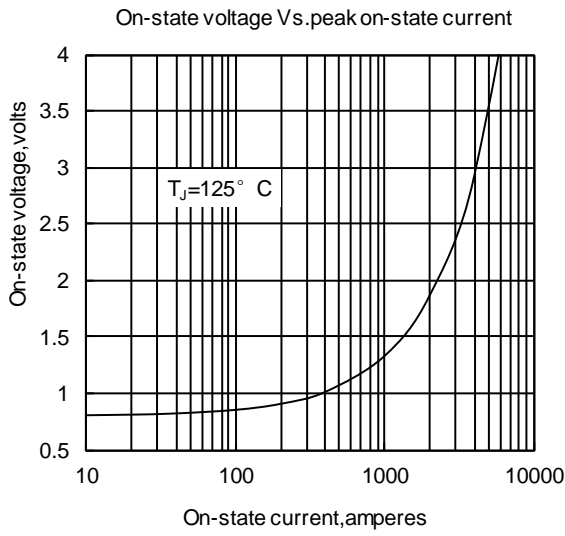

Fig1

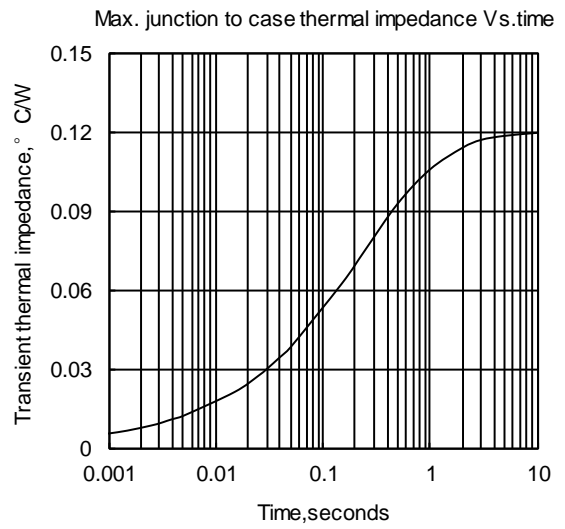

Fig2

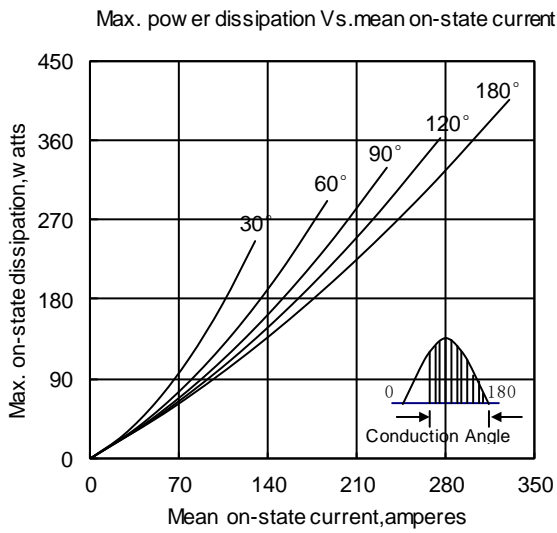

Fig3

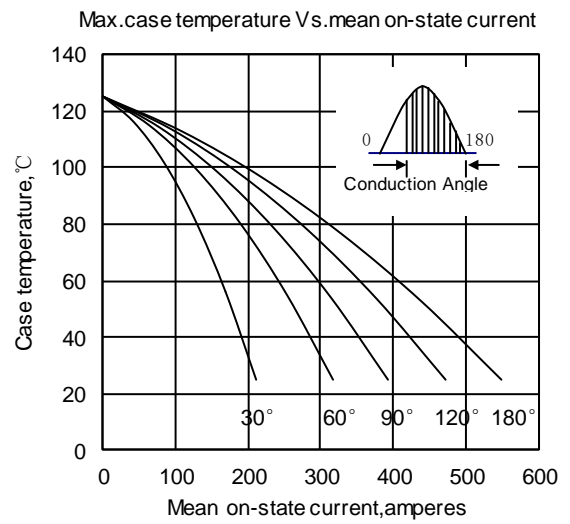

Fig4

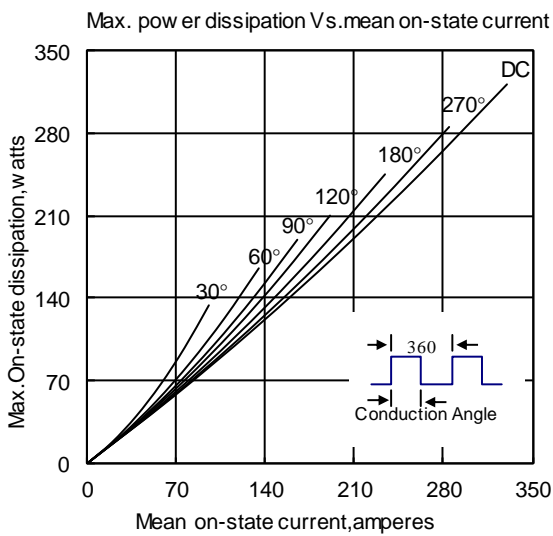

Fig5

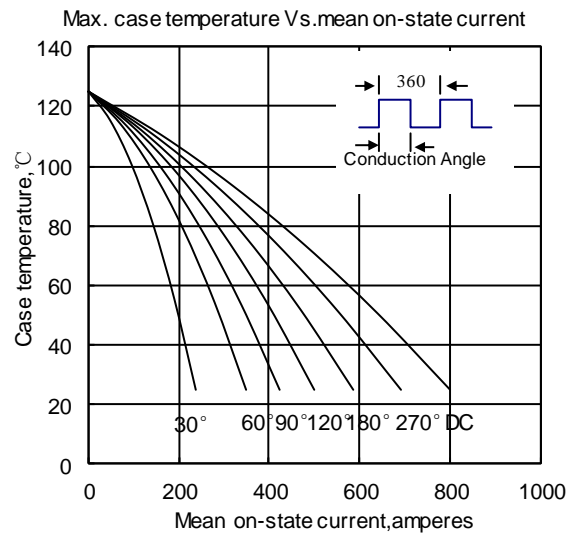

Fig6

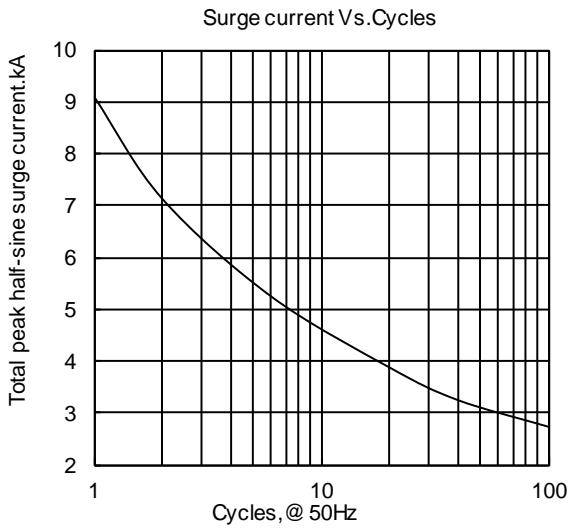

Fig7

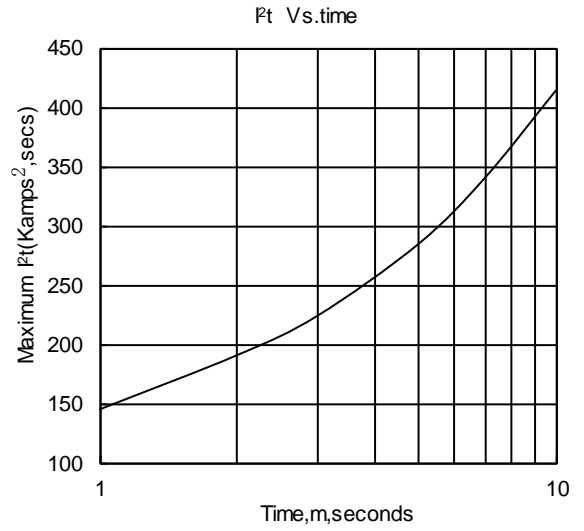

Fig8

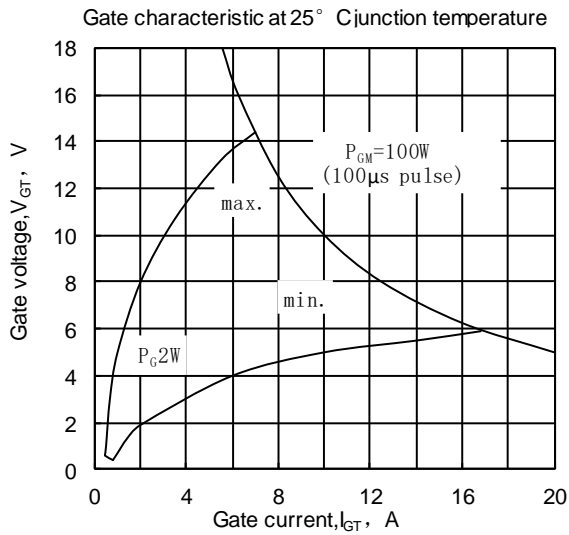

Fig9

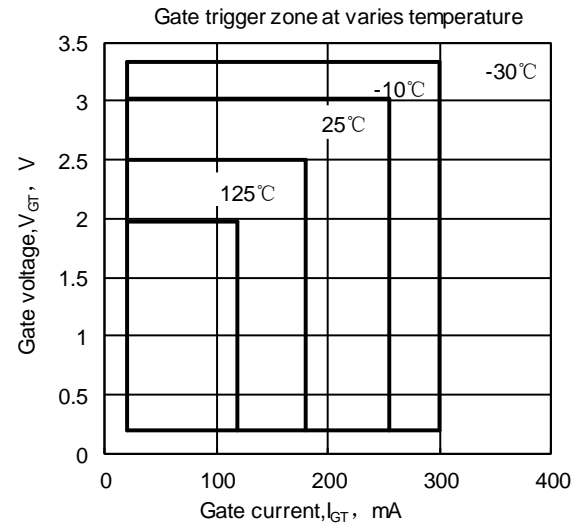
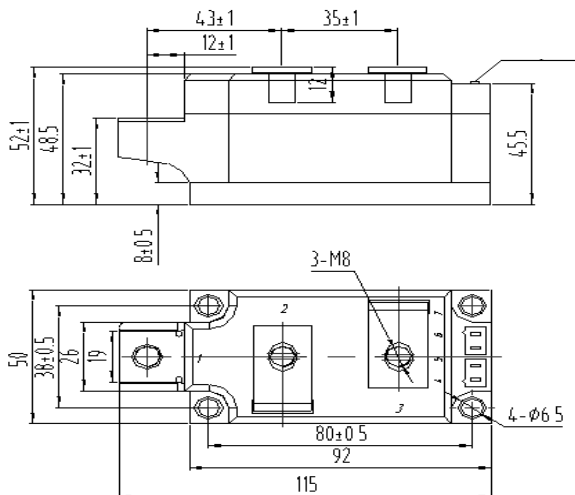
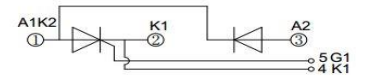

Fig10



MD330TH\*\*



MR330TH\*\*

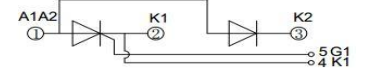

MC330TH\*\*

