

Features :

- Isolated mounting base 2500V~
- Pressure contact technology with Increased power cycling capability
- Space and weight saving

Typical Applications

- Inverter
- Inductive heating
- Chopper

V _{DSM} , V _{RSM}	V _{DRM} , V _{RRM}	品名
900V	800V	Mx400THF80
1100V	1000V	Mx400THF100
1300V	1200V	Mx400THF120
1500V	1400V	Mx400THF140
1700V	1600V	Mx400THF160

SYMBOL	CHARACTERISTIC	TEST CONDITIONS	T _j (°C)	VALUE			UNIT
				Min.	Typ.	Max.	
I _{T(AV)}	Mean on-state current	180° half sine wave 50Hz Single side cooled, T _c =55°C	125			400	A
I _{T(RMS)}	RMS on-state current					628	A
I _{DRM} I _{RRM}	Repetitive peak current	at V _{DRM} at V _{RRM}	125			100	mA
I _{TSM}	Surge on-state current	10ms half sine wave V _R =60%V _{RRM}	125			7.8	kA
I ² t	I ² t for fusing coordination					310	A ² s*10 ³
V _{TO}	Threshold voltage		125			1.20	V
r _T	On-state slope resistance					0.47	mΩ
V _{TM}	Peak on-state voltage	I _{TM} =1200A	25			2.40	V
dv/dt	Critical rate of rise of off-state voltage	V _{DM} =67%V _{DRM}	125			800	V/μs
di/dt	Critical rate of rise of on-state current	Gate source 1.5A t _r ≤0.5μs Repetitive	125			200	A/μs
t _q	Circuit commutated turn-off time	I _{TM} = 300A, t _p =2000μs, V _R =50V dv/dt=30V/μs , di/dt=-20A/μs	125	20		40	μs
t _{rr}	Reverse recovery time	I _{TM} =300A, t _p =2000μs, -di/dt=20A/μs, V _R =50V	125		5		μs
I _{GT}	Gate trigger current	V _A =12V, I _A =1A	25	30		200	mA
V _{GT}	Gate trigger voltage			1.0		3.0	V
I _H	Holding current			20		200	mA
V _{GD}	Non-trigger gate voltage	V _{DM} = 67%V _{DRM}	125	0.2			V
R _{th(j-c)}	Thermal resistance Junction to case	D.C. Single side cooled per chip				0.060	°C /W
R _{th(c-h)}	Thermal resistance case to heatsink	D.C. Single side cooled per chip				0.040	°C /W
V _{iso}	Isolation voltage	50Hz, R.M.S, t=1min, I _{iso} : 1mA(MAX)		2500			V
F _m	Terminal connection torque(M12)				14.0		N·m
	Mounting torque(M8)				12.0		N·m
T _{vj}	Junction temperature			-40		125	°C
T _{stg}	Stored temperature			-40		125	°C
W _t	Weight				3660		g
Outline	M07						

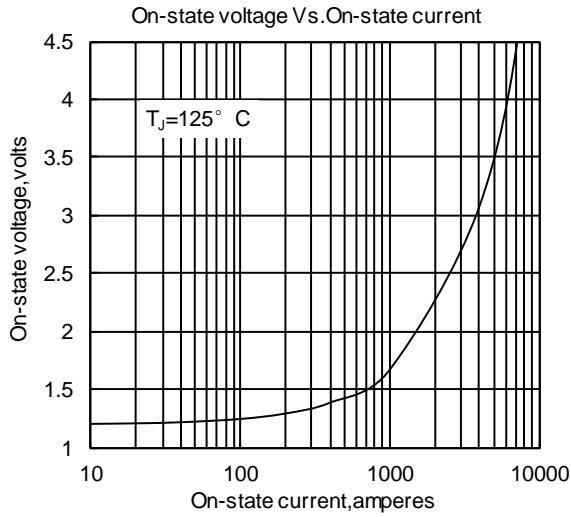

Fig.1

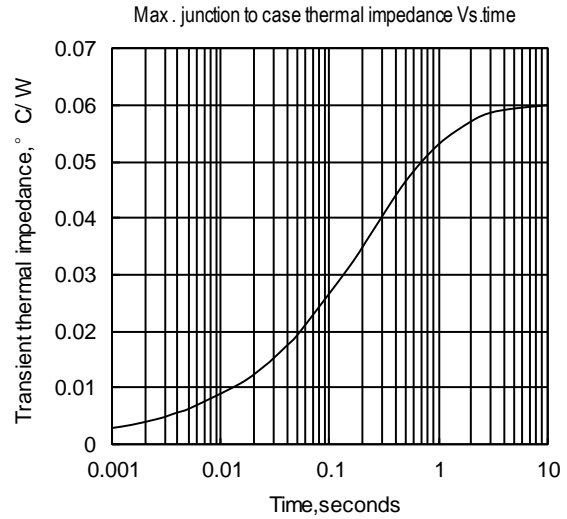

Fig.2

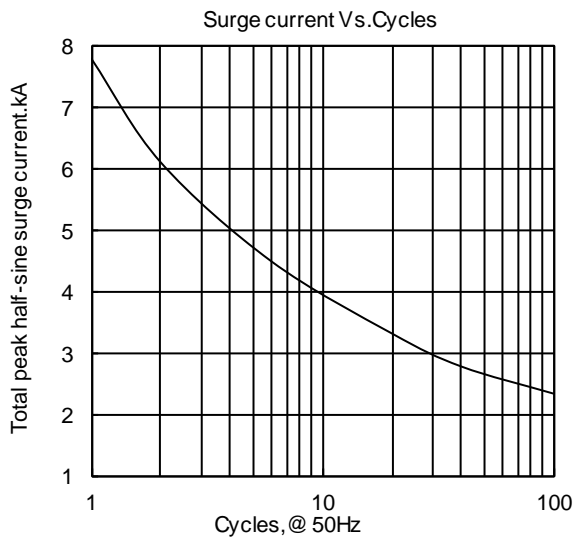

Fig.3

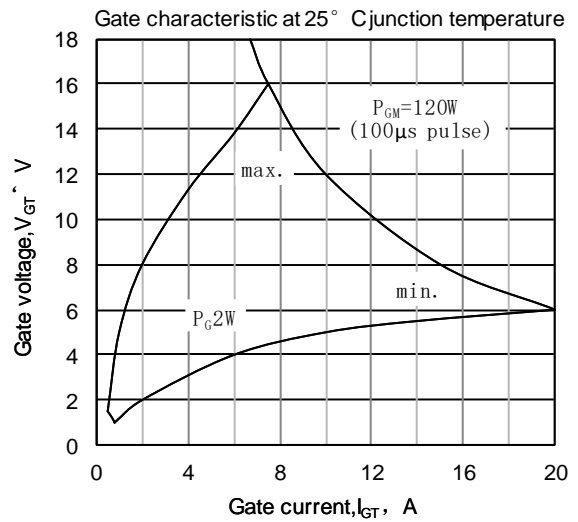

Fig.4

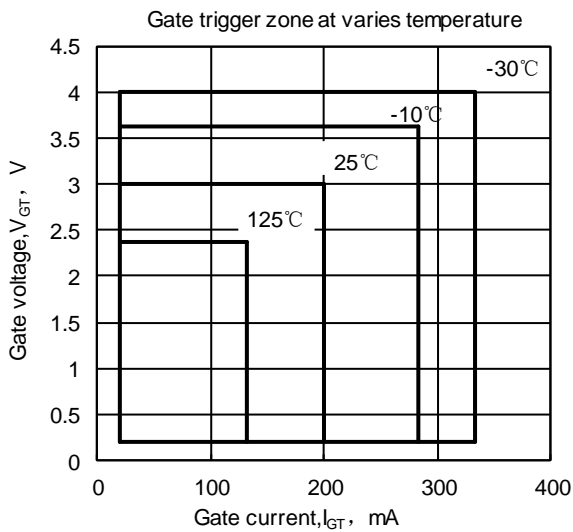
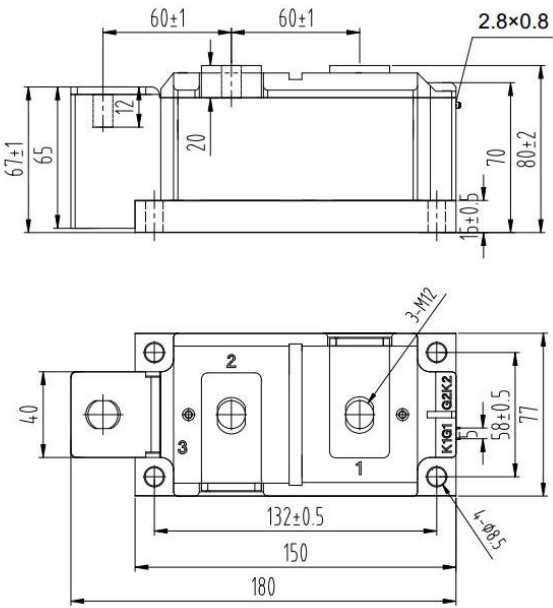
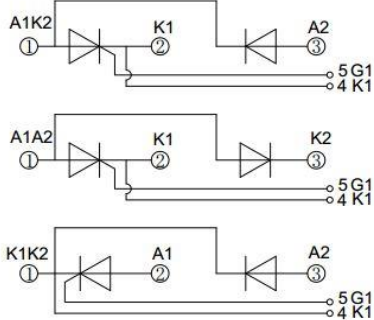

Fig.5



MD400THF**
 MR400THF**
 MC400THF**



Unmarked dimensional tolerance : ±0.5mm

Nlps reserves the right to change specifications without notice.