

Features :

- Isolated mounting base 3000V~
- Pressure contact technology with
Increased power cycling capability
- Space and weight saving

Typical Applications

- AC/DC Motor drives
- Various rectifiers
- DC supply for PWM inverter

V_{DSM}, V_{RSM}	V_{DRM}, V_{RRM}	品名
2100V	2000V	Mx90T200
2300V	2200V	Mx90T220
2600V	2500V	Mx90T250

SYMBOL	CHARACTERISTIC	TEST CONDITIONS	T_j (°C)	VALUE			UNIT
				Min.	Typ.	Max.	
$I_{T(AV)}$	Mean on-state current	180° half sine wave 50Hz Single side cooled, $T_c=85^\circ\text{C}$	125			90	A
$I_{T(RMS)}$	RMS on-state current					141	A
I_{DRM} I_{RRM}	Repetitive peak current	at V_{DRM} at V_{RRM}	125			15	mA
I_{TSM}	Surge on-state current	10ms half sine wave	125			1.50	kA
I^2t	I^2t for fusing coordination	$V_R=60\%V_{RRM}$				11.25	$\text{A}^2\text{s}\cdot 10^3$
V_{TO}	Threshold voltage		125			0.85	V
r_T	On-state slope resistance					3.26	mΩ
V_{TM}	Peak on-state voltage	$I_{TM}=270\text{A}$	25			1.93	V
dv/dt	Critical rate of rise of off-state voltage	$V_{DM}=67\%V_{DRM}$	125			800	V/μs
di/dt	Critical rate of rise of on-state current	Gate source 1.5A $t_r \leq 0.5\mu\text{s}$ Repetitive	125			100	A/μs
I_{GT}	Gate trigger current	$V_A=12\text{V}, I_A=1\text{A}$	25	30		100	mA
V_{GT}	Gate trigger voltage			0.7		2.5	V
I_H	Holding current			10		150	mA
V_{GD}	Non-trigger gate voltage	$V_{DM}=67\%V_{DRM}$	125	0.2			V
$R_{th(j-c)}$	Thermal resistance Junction to case	D.C. Single side cooled				0.28	°C/W
$R_{th(c-h)}$	Thermal resistance case to heat sink	D.C. Single side cooled				0.15	°C/W
V_{iso}	Isolation voltage	50Hz, R.M.S, $t=1\text{min}, I_{iso}: 1\text{mA}(\text{MAX})$		3000			V
F_m	Terminal connection torque (M5)			2.4		3.0	N·m
	Mounting torque (M6)				6.0		N·m
T_{vj}	Junction temperature			-40		125	°C
T_{stg}	Stored temperature			-40		125	°C
W_t	Weight				170		g
Outline	M01						

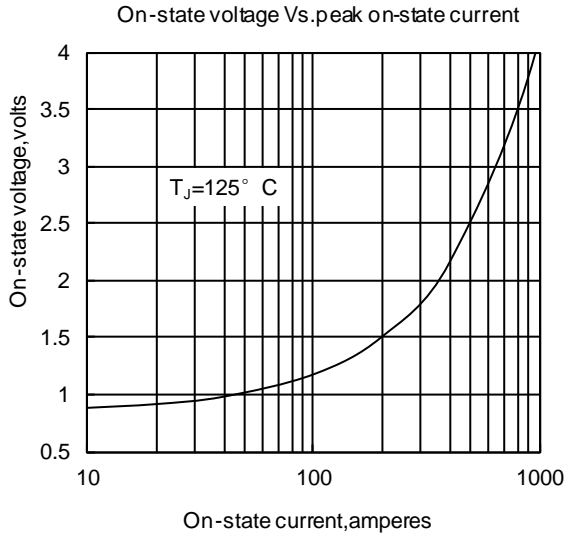

Fig. 1

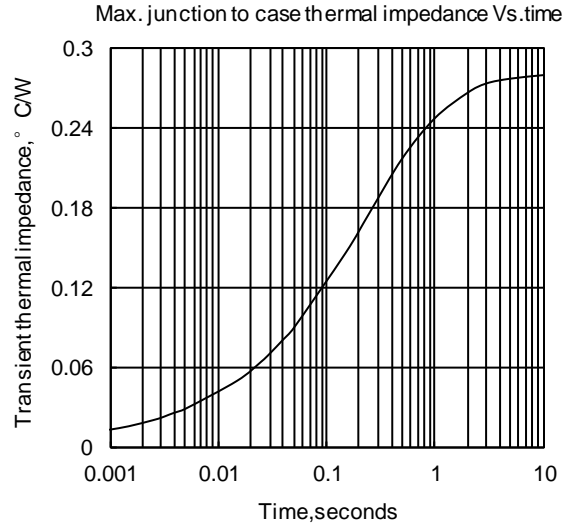

Fig. 2

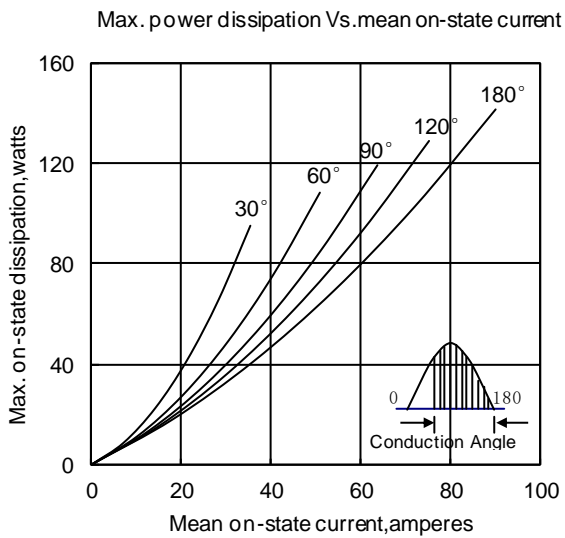

Fig. 3

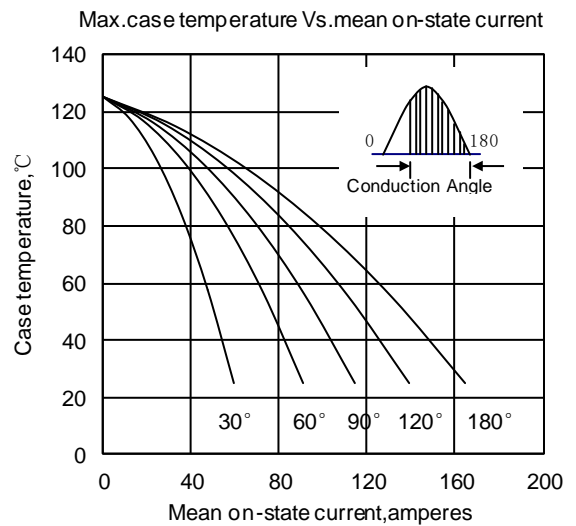

Fig. 4

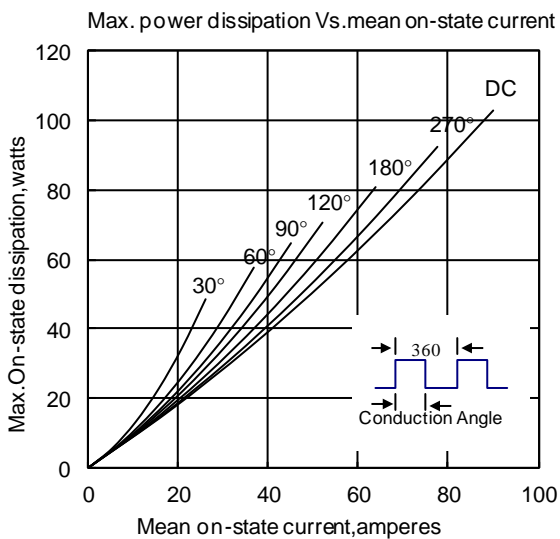

Fig. 5

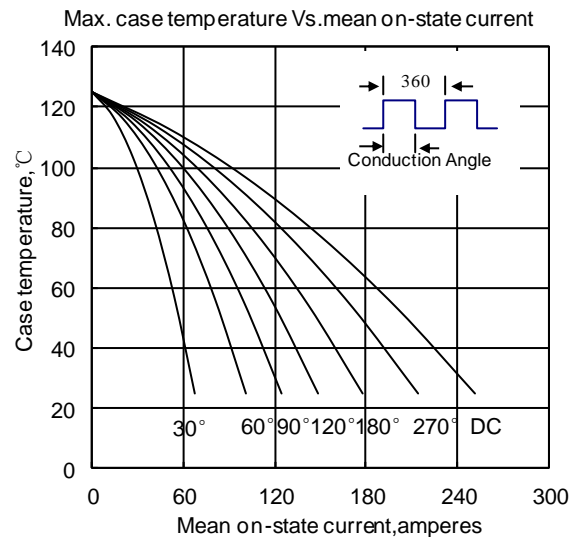

Fig. 6

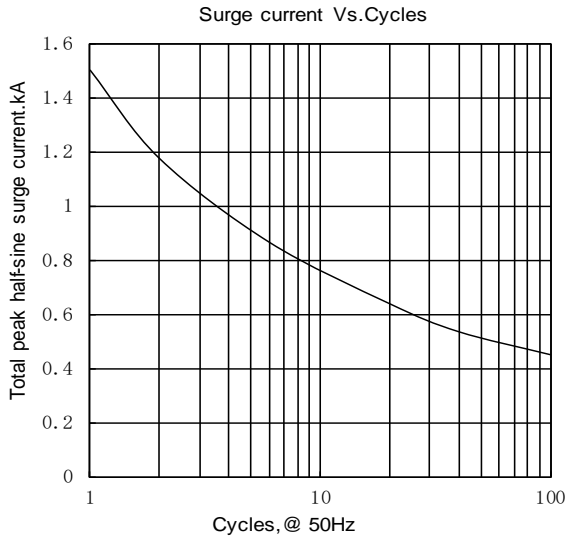

Fig.7

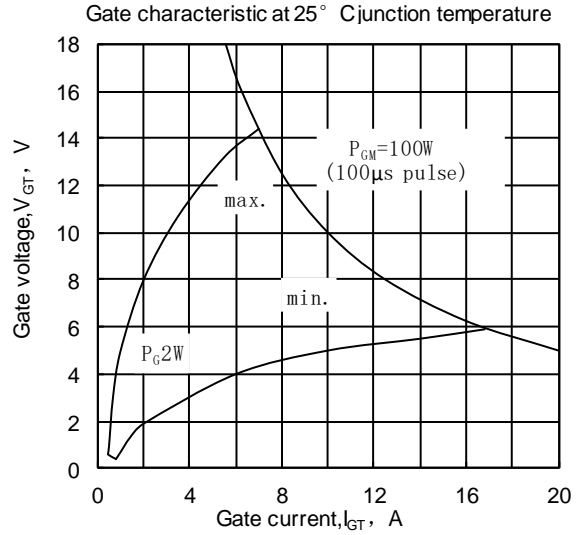

Fig8

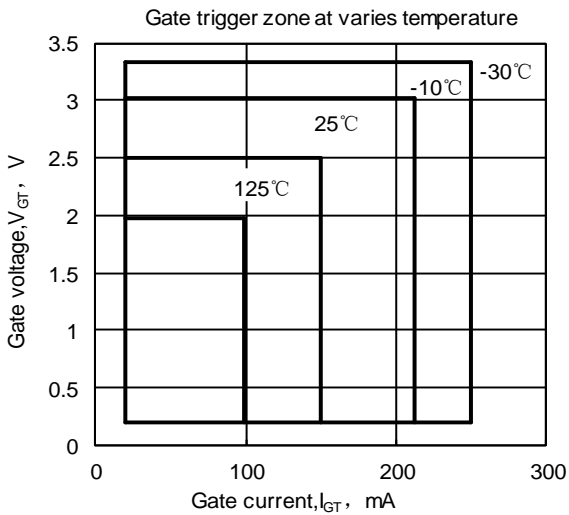
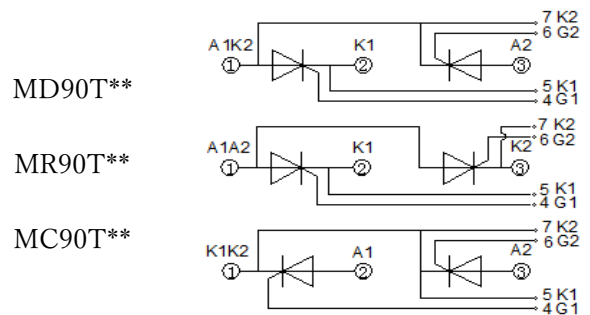
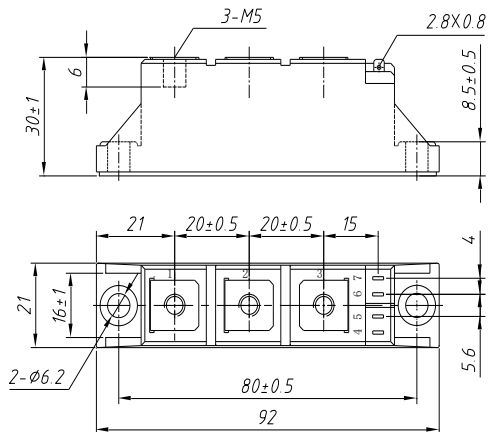

Fig9



Unmarked dimensional tolerance : ±0.5mm

Nlps reserves the right to change specifications without notice.